

All Illustrations in this document were done by myself, James Salaz. The keyboard below was done with Corel Draw. It was extruded for a 3D effect, making it fully rotational. The remaining drawings were done with Visio 2000.

Pan Tilt Zoom Camera Controller

User Guide

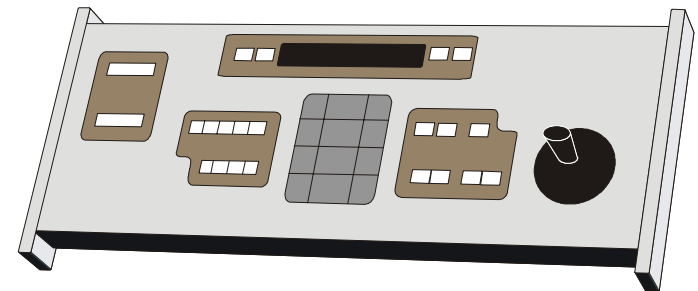

1. General Introduction

This controller is designed for specific use with the ASL Speed Dome Camera. Both Controller and Camera are connected via EIA/RS485 connector. This controller can operate from 1 to 32 Speed Domes. The communication distance between the controller and receiver is up to 1.2km. It's very easy to operate and set up the Speed Dome Camera with this controller.

The controller is also able to control the terminal receiver to achieve the function of controlling pan/tilt, lens, light, wiper, etc.

2. Main Function

The controller has the following main functions:

- a) To set up the address from 0 to 64 for Speed Dome Cameras.
- b) To directly control all functions of the Speed Dome Camera. For example: turn the camera power ON and OFF.
- c) To operate the pan/tilt of the Speed Dome Camera at different speed levels.
- d) To set up 64 preset positions and 6 cruising tracks for the Speed Dome Cameras, and call any of them. Each cruising track contains up to 16 preset positions. You can set up the duration and speed for each preset position.
- e) To control the Speed Dome Camera by manual or auto operation.
- f) To manually control the camera Zoom, Iris, and Focus.
- g) To control up to 32 Speed Dome Cameras.

3. Front Panel & Rear Panel

3.1: Front Panel. (Diagram 1):

The front panel consists of a joystick, numeric and function keys, and an LCD screen. The LCD screen displays system status and provides a setup dialogue. Joystick is used for manually rotating the pan/tilt in four directions.

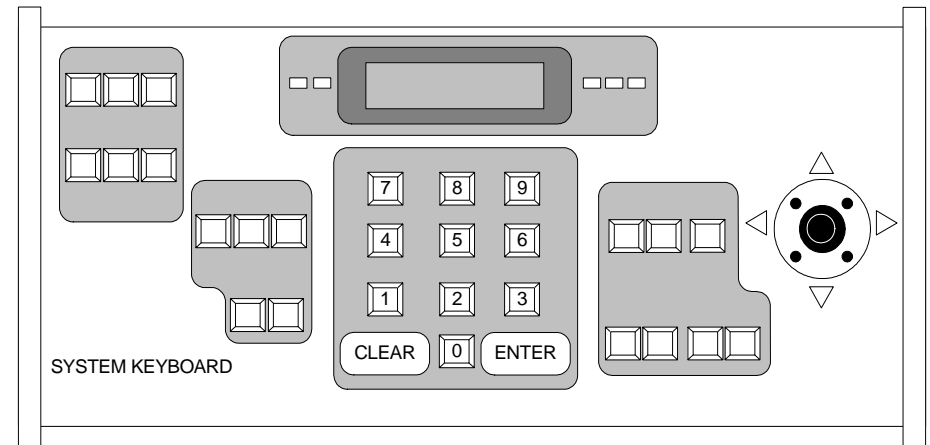

Diagram 1

Key Function:

[MON]	To select monitor (only used when connected to a matrix.)
[CAM]	To select Speed Dome Camera
[LAST]	To call the previous camera to the current monitor
[NEXT]	To call the next camera to the current monitor
[SHOT]	To set up or call cruising track
[PRESET]	To set up preset position
[CALL]	To call the preset position
[RUN]	Sequence switching
[SALVO]	Simultaneous switching
[ALARM]	Alarm set up
[ON]	To turn on the function setting
[OFF]	To turn off the function setting
[F1], [F2]	Auxiliary function keys
[F3]	To preset alarm function / to cancel preset alarm function
[0] – [9]	Number key
[CLEAR]	To clear
[ENTER]	To confirm
[AUTO]	To control auto-horizontal rotation for pan/tilt
[OPEN]	To open the Iris
[CLOSE]	To close the Iris
[WIDE]	To a wide angle
[TELE]	To turn to a telescopic range
[FAR]	To manually focus far
[NEAR]	To manually focus near

3.2 Rear Panel (Diagram 2)

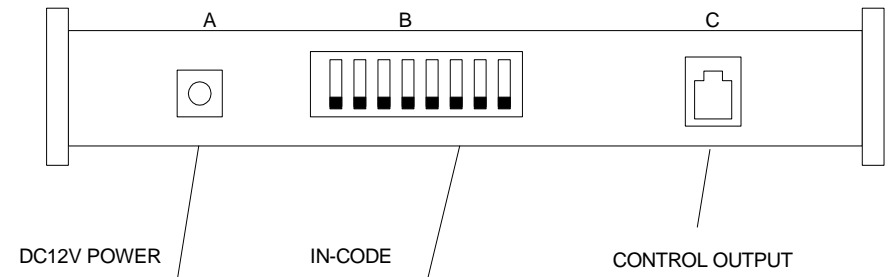

Diagram 2

- A. Power input connector: input DC12v power
- B. Code switch: Used for setting up the keyboard address when the system is connected to a matrix. When the keyboard controls the front port device, (ID-CODE only select “OFF”)
- C. Communication connector

The controller is connected to adapter box by specific cable.

4. Keyboard Operation

The following operations are available for the selected Speed Dome Camera. The Speed Dome Camera numbers must be set before operating them. Before operating the keyboard, the LCD screen displays:

Current Cam ID: ‘N’

‘N’ is the current Speed Dome Camera number.

4.1: To set the camera ID: [CAM] N1 [ON] N2 [OFF]

N1: the destination camera ID (address) (0 to 255)

N2: ten digit serial number

The LCD displays:

Enter the 8 digit serial number from the side of the camera. Add two zeros to the end of the number:

“1234567800” – correct

“0012345678” – incorrect! Camera will not work.

If the 10 digit serial number has been input correctly, when the OFF key is pressed, the serial number is changed and corresponds with the destination camera ID.

4.2: To select the number “N” camera: [CAM] N [ENTER]

The LCD displays:

N: camera number 0 – 64

The following commands are available to all Speed Dome Cameras when the address is set to “0”.

4.3: To set the preset position: [PRESET] N [ENTER]

The LCD displays:

N: the number of preset position 1 – 64.

4.4: To call the preset position [CALL] N [ENTER]

The LCD displays:

4.5: To set up cruise tracks: [SHOT] N [ON]

The LCD displays:

N: the track number: 1 – 6

The LCD displays:

(N₁: Track number, N₂: Sum of preset positions)

Press [TELE], the LCD will display: No.1 Point_____.

Enter the number of the preset position for the first point in this track. (Preset position range: 1 – 64)

Press [TELE] again, the LCD displays: No.1 Speed_____.

Enter the speed of the first point in this track (Speed level: 1 – 8), and then press [TELE:], the LCD displays: No. 1 Time_____.

Enter the duration of the first point in this track. (Time range: 1 – 99 sec.)

Use the same method to set the up to 16 points in the track.

Press [TELE] key to down page.

Press [WIDE] key to up page.

The preset points are available in the track before the position of the number N preset point that is set to “0”. After the “0” point position, preset point number, speed level, and duration are all set to “0” automatically.

In the Speed set up menu, 1 is the highest level, 8 is the lowest level. Any speed values not in this range will be considered the highest level.

Press OFF to save and exit.

Move the joystick to exit without saving.

4.6: To call the number N track: [SHOT] N [ENTER]

The LCD displays:

N: the number of track: 1 – 6

4.7: To turn on Auto Pan: [AUTO] [ON]

Press Auto, the LCD displays:

Auto On.

4.8: To turn off Auto Pan: [AUTO] [OFF]

Press Auto, the LCD displays:

Auto Off.

4.9: Zoom is adjusted to a wide-angle view: [WIDE]

The LCD displays:

Zoom Wide.

4.10: Zoom is adjusted to a telescopic picture: [TELE]

The LCD displays:

Zoom Tele.

4.11: Focus is adjusted to far: [FAR]

The LCD displays:

Focus Far.

4.12: Focus adjusted to near [NEAR]

The LCD displays:

Focus Near.

4.13: To open IRIS: [OPEN]

The LCD displays:

Iris Open.

4.14: To close IRIS [CLOSE]

The LCD displays:

Iris Close.

4.15: Define auxiliary function key [F1]

Value of N	Target of controlling	Definition of keyboard operation	
		[F1]+N+[ON]	[F1]+N+[OFF]
1	Backlight compensation	ON	OFF
4	Digital zoom	ON	OFF
5	LCD backlight	ON	OFF
6	Focus	AUTO	MANUAL
9	Mirror picture	MIRROR	STANDARD
12	Receiver controlling	ON	OFF
13		ON	OFF
14		ON	OFF
15		ON	OFF
16		ON	OFF

For example: [F1]+1+[ON] means turning on BLC function.

[F1]+1+[OFF] means: turning off BLC function.

[F1]+13+[ON] means: running the wiper.

The general operations are listed in the above table. Some operations are selectable for different cameras. For example: Not all cameras have the “0” illumination function.

The operation for changing the menu is as follows when camera

displays a menu:

- A. Open the menu according to the ways listed in the above table.
- B. Select the menu option using [WIDE] / [TELE] keys to move cursor up or down.
- C. Change the menu option status using [FAR] / [ENTER] keys.
- D. Close the menu according to the method listed in the table after finishing the menu set up.

4.16: How to control the Speed Dome Camera viewpoint (pan / tilt position) (Diagram 3)

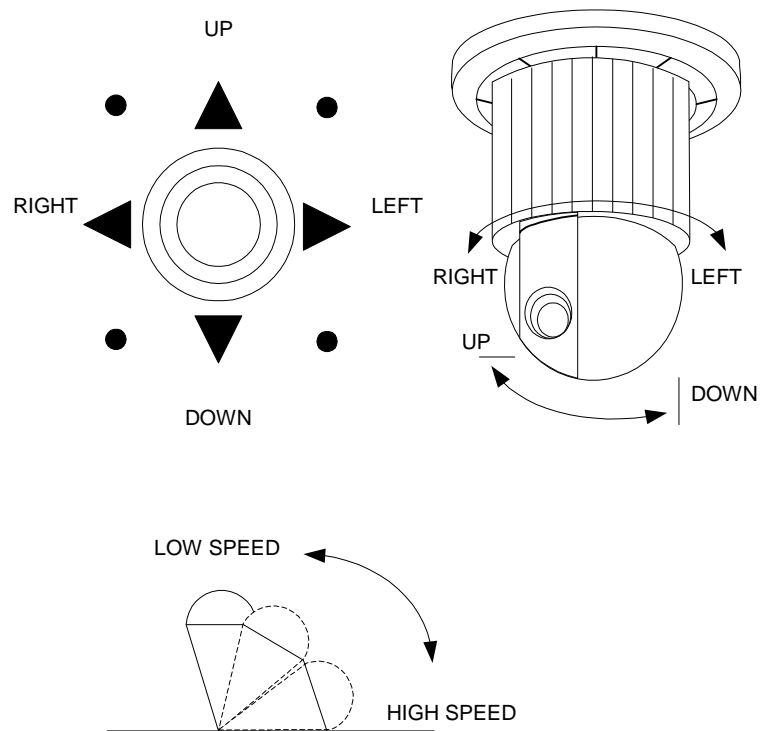

Diagram 3

Normally, the Speed Dome Camera supports hemispheric viewpoints (pan 360° and tilt 180°). The speed of dome movement depends on the angle of the joystick, the more you push the joystick, the faster the dome will move. The cameras will keep the perfect picture through auto-focus function during movement.

4.17: If the operator makes a mistake, the LCD will display “Error Operation” for 1 second and then return to standard status.

5. Installation and Connection (Diagram 4)

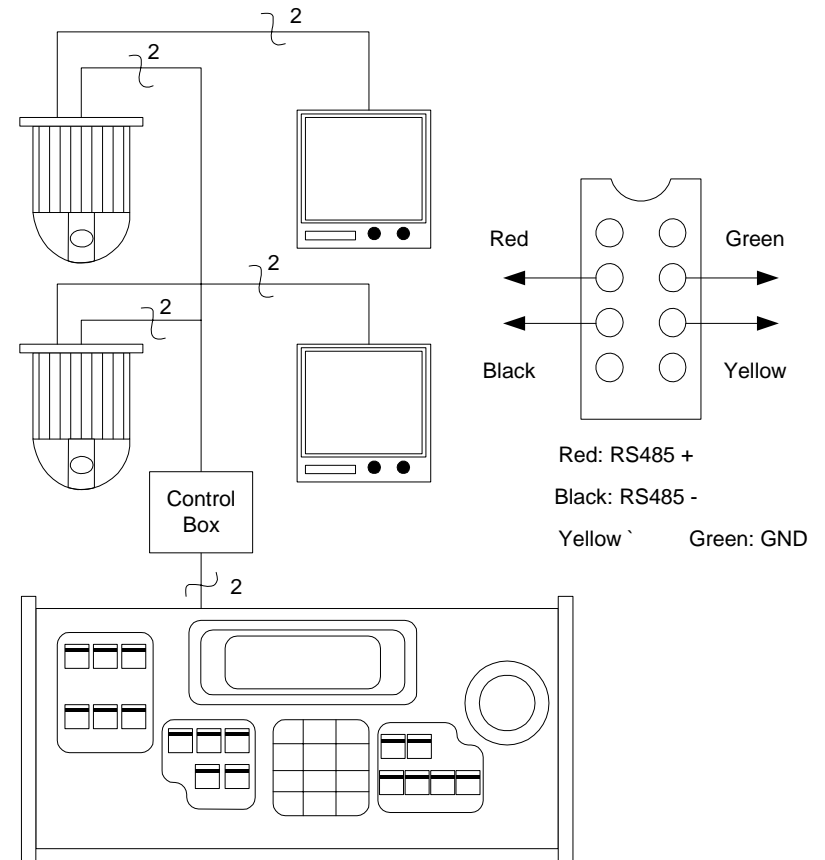

Diagram 4

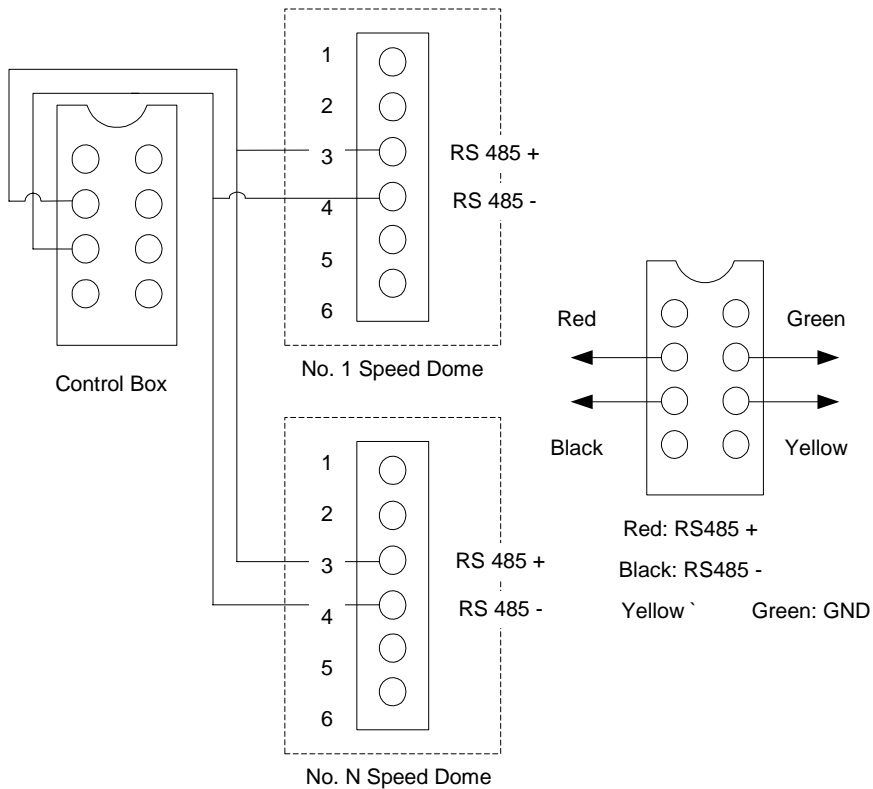

Diagram 5

Additional commands

1. Del Preset [CLEAR] N [ENTER] (N=1-63)
2. Start Sequence [SHOT] N [ENTER] (N=1-4)
3. Clear Sequence [SHOT] N [ENTER] (N=1-4)
4. Set Seq. Dwell Time [SHOT] N [ON] (N= 0-255)
Attention: Set the dwell time *before* setting a preset.
5. Set the start point of Auto Scan [AUTO] [ON]
6. Set the end point of Auto Scan [AUTO] [OFF]
7. Set the speed of Auto Scan and run it [AUTO] N [ENTER]

8. Additional function:

Camera function: N1=0 – 255, N2=0 – 255 [F1] N1 [ON] N2 [OFF]

N1	N2	ACTION
0	0 – 255	CAM reset
6	0	WB Auto
	1	WB Indoor
	2	WB Outdoor
	3	One Push WB
	4	ATW WB
8	5	WB Manual
	0	On Screen Display On
9	Not 0	On Screen Display Off
	0	Digital Zoom On
13	Not 0	Digital Zoom Off
	0	Iris Auto
14	Not 0	Iris Manual
	0	Back Light On
21	Not 0	Back Light Off
	0	Zero Lux On
255	1	Zero Lux Off
	0	Dome Reset

- Save preset with speed [F2] N1 [ON] N2 [OFF]
(N1: preset number 1 – 63 N2: speed of call preset 0 – 128)
- Insert preset in Seq. [F3] N1 [ON] N2 [OFF]
(N1: preset number 1 – 63 N2: Seq. number 1 – 4)
- IR filter off time [ALARM] N1 [ON] N2 [OFF]
(N1: 0 – 23 N2: 0 – 59)
- IR filter ON time [RUN] N1 [ON] N2 [OFF]
(N1: 0 – 23 N2: 1 – 255)
- Start record pattern [SALVO] N1 [ON] N2 [OFF]
N1: 1 – 4 N2: 1 – 255

- End record pattern [SALVO] N1 [ON] 0 [OFF]
(N1: 1 – 4)
- Run pattern [SALVO] N1 [ENTER]
(N1: 1 – 4)
- Assistant switch on/off [NEXT] N1 [ON] N2 [OFF]
(N1: 1 – 255, N2: 0/1)
- Auto home function: [MON] N1 [ON] N2 [OFF]
(N1: = 0, auto home function off N2 home time 0 – 255 Not 0, auto home function on)

SW2 Baud Settings:

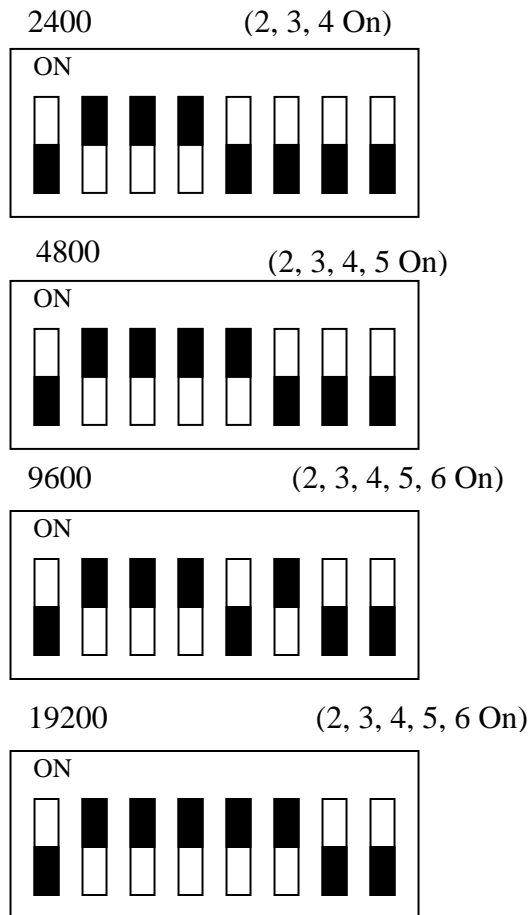

Caution:

Please read the manuals of our controller and Speed Dome Camera carefully before installation. Any incorrect operation will lead to damage of the device. Turn off the power before installing the device, and shielded twisted – pair cable should be used for communication of the devices. Keep the device away from high – power areas and electromagnetic interference.

5.1: How to control multiple Speed Dome Cameras with a keyboard, as shown in the previous illustration (Diagram 4).

5.2: How to connect the controller to the Speed Dome Camera, as shown in the following illustration (Diagram 5).

6. Specifications:

6.1: Communication between Speed Dome Camera and controller port to multi – port and half duplex function.

6.2: Communication protocol: RS485

6.3: Communication speed: 4800bps (A01).

6.4: Communication distance: 1200 m.

6.5: Power DC12V

6.6: Dimensions: 380 x 165 x 80 (mm)

6.7: Weight: 2kg

6.8: The number of controlled Speed Dome Cameras up to 32.