

# AFRC

(Adjustable Electric Fan Relay Controller)  
Can be use with any 0-5V sensor signal.

The AFRC module is intended to operate a Bosch type automotive relay by switching one side of the relay drive coil to ground, the other side of the coil connects to 12V. The relay is triggered based on a user selected voltage threshold of any 0V to 5V sensor signal. As an E-Fan relay controller our module snoops the voltage on the temperature sensor that the PCM/ECM is already using so no extra sensor is required. The temperature sensor can be the standard automotive type that decreases in resistance as temperature increases (NTC) or it can be the PTC type that increases with temperature. Please specify NTC (standard) or PTC when ordering.

The vehicle must not change its measuring sensitivity (supply impedance) over the temperature range otherwise the voltage on the sensor will jump and the module will false trigger at some settings. **This excludes the GM LS1 and Vortec.**

In the standard version, the three slide switches on the front of the module set the relay turn on voltage threshold starting at 4.9V and can be adjusted down to 0.1V (in seven 0.7v steps) with a 0.1V turn off hysteresis threshold to reduce relay and fan cycling. The standard settings are (NTC, 4.9V-0.1V, 0.1V hysteresis). For custom AFRC modules please specify (NTC/PTC, User adjustable voltage range, turn off hysteresis voltage). If you are unsure of how to specify custom module setting just let us know.

The module will flash the switch setting (0-7) on the LED to confirm your settings at power up and upon waking from sleep (only if the switch settings have been changed). During normal operation the module will flash its LED every five seconds, one flash if the fan relay should be off and two flashes if the fan relay should be on. Changes in fan status (on/off) or to new switch settings only take effect at the next wakeup period, which happens every five seconds.

## Features:

- Reverse voltage protection in the event of incorrect power connections
- Low current (5 - 8mA)
- Output wire can sink up to 1.5A
- Internal flyback diode to reduce voltage spikes
- Indicator LED to confirm operation and indicate mode
- Light weight (1.06oz)
- Small package (2.12in. by 1.38in. by 0.58in.)
- 12 month warranty from date of purchase against manufacturer defects

## Typical wiring:

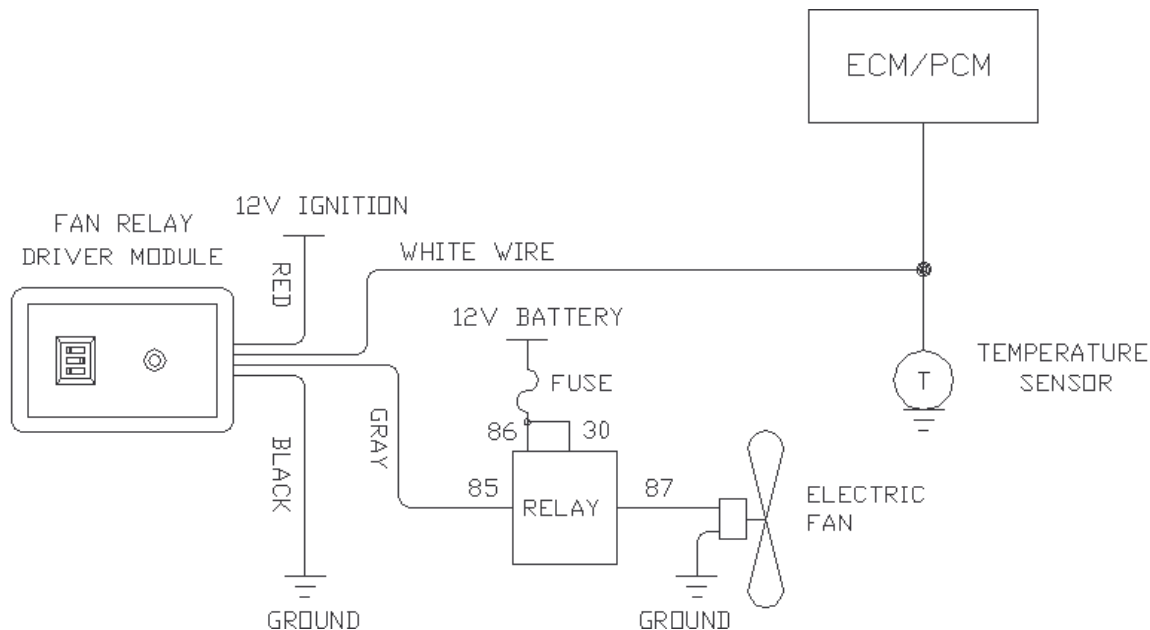

Any 12V relay can be used as long as the N.O. (normally open) contacts are rated for the maximum current of the electric fan load.

## Bosch type relay (not included):

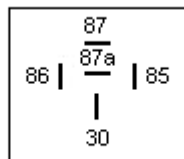

COM: 30  
NO: 87  
NC: 87a  
Coil: 85, 86

Bottom view

## AFRC Wires:

- **Red:** 12V ignition
- **Gray:** Relay driver output, capable of sinking 1.5A to ground, connect to low side of FAN relay coil.
- **White:** Temperature sense wire. This wire snoops the 0-5 volt signal from the temperature sensor to the ECM (engine control module).
- **Yellow:** AC Override. 12 volts signal applied to this wire activates output regardless of temperature.\*
- **Black:** Ground

\* **Yellow will only be present if AC Override option is requested.**

We recommend connecting the four wires by using insulated crimps or soldering and using appropriate insulation electrical tape or heat-shrink tubing. The 12V supply to pins 86 and 30 of the relay should be connected through an appropriate fuse.

### Adjusting the turn on threshold:

The AFRC module has three slide switches on it that can each be turned either 'on' (up towards LED) or 'off' (away from LED) allowing the user to adjust it to eight different settings: 000 or (off, off, off), 001, 010, 011...111 or (on, on, on). The eight settings (0-7) are in binary format, increment the binary setting for a hotter turn on temperature or decrement the setting for colder. See table below.

Normally for electric fans applications an adjustable range from 140F to 200F is all that is needed. If the AFRC were customized to this 60F range it would give approximately 7.5F steps to the settings: 140F, 148F, 155F... 200F. The smaller the adjustable range the finer the steps will be. Our standard version is set to give the full range 0.1V to 4.9V this can result in adjustable steps of 60F or more so **you may not be able to set the temperature you want unless you have us customize your order.**

### Switch setting table for the standard version (NTC, 4.9V-0.1V, 0.1V hysteresis):

Switches (1,2,3)	Turn on threshold	Turn off threshold (0.1V colder)	
0* (000) (off, off, off)	4.8V	4.9V	Coldest
1 (001) (off, off, on)	4.1V	4.2V	
2 (010)	3.4V	3.5V	
3 (011)	2.7V	2.8V	
4 (100)	2.0V	2.1V	
5 (101)	1.3V	1.4V	
6 (110)	0.6V	0.7V	
7 (111)	0.1V	0.2V	Hottest

\* Note: the LED flash code for the zero setting is one long pulse.

For warranty service, questions, or comments regarding this or any of our products, please contact Baker Electronix at [bakerelectronix@verizon.net](mailto:bakerelectronix@verizon.net).